



Front Load Washer

FFFW5000QW

7 Wash Cycles
3.9 Cu. Ft. D.O.E.



Optional SpaceWise® Pedestal Drawer Shown

Signature Features

Advance Rinse Technology

Final rinse uses fresh water to ensure whiter whites and reduce allergens.

Stainless Steel Drum

Smooth, durable interior is rust-proof and won't snag clothes.

Large Capacity

Finish more in less time with our 3.9 cu.ft. D.O.E. capacity — the washer can fit two baskets of laundry in a single load.

Tumble Action Cleaning System

By removing the agitator, you can count on the tumble action to wash gently and rinse completely, ensuring your clothes feel fresher and last longer.

Product Dimensions

Height	36"
Width	27"
Depth	30-9/16"

More Easy To Use Features

ENERGY STAR®-Qualified

Stain Clean Option

Delay Start

Begin your washing cycle at the time that works best with your schedule.

End-Of-Cycle Signal

Ready-Select® Controls

It's easy to get laundry started with just the touch of a button.

TimeWise® Technology

Wash time equals dry time — so you don't wait for clothes to dry.

SilentDesign™

Designed for quiet operation.

Stay-Fresh™ Antimicrobial Seal

Auto Options

Automatic Water Level Control

Optional Pedestal Drawer

Vibration Control System

Advanced vibration control keeps even oversized loads balanced for smooth, quiet operation. Ideal for second floor installation.

Add-a-Garment

With just the touch of a button, easily add an extra piece to the washer once a cycle has started.

ENERGY STAR®



Available in:



Classic White (W)

Features	
Total Capacity D.O.E. (Cu.Ft.)	3.9
Controls	Ready-Select*
Washer Drum Interior	Stainless Steel
Lifetime Warranty Tub	Yes
Interior Light/ Door Trim	No/White
Vibration Control System	Yes
Advanced Rinse Technology	Yes
TimeWise* Technology	Yes
Ready Clean™/Ready Steam™	
Fresh Water Rinse Option	Yes
Stay-Fresh™ Door Seal	Yes
Automatic Temperature Control	Yes
Automatic Water Level Adjustments	Yes
Auto Prewash Detergent Dispenser	
Auto Bleach Dispenser	Yes
Auto Detergent Dispenser	Yes
Auto Fabric Softener Dispenser	Yes
Time Remaining Indicator	Yes
Cycle Status Lights	Yes
Cycle Signal/Cycle Signal "On/Off"	Chime/Yes
Cycle Signal Volume Control	
Door Lock Indicator Light	Yes
Control Lock/Stay Put Door	Yes/Yes
Start/Pause/Cancel Buttons	Yes
Energy Saver Option	Yes
Delay Start	Up to 10 Hours
Integral Water Heater	
Tumble Speed (RPM)	Variable
Spin Speed (Maximum RPM)	1,200
Sound Package	SilentDesign™
Adjustable Leveling Legs	Yes
Cycles	
Wash Cycles/Specialty Cycles	7/0
Options	
Water Temperature Selections	5
Water Levels	Automatic/Max Fill
Spin Speed/Soil Level Selections	5/5
Allergen	
Optional Accessories	
Dryer Stacking Kit	PN# STACKIT4X
15" Frigidaire® Pedestal Drawers	
Classic White (W)	PN# CFPWD15W
Mobile Home Installation Kit	PN# 137067200
Drain Hose Extension Kit	PN# 137098000
6' Stainless Steel Washer Fill Hose (2 pack)	PN# 5305516562
4' Rubber Washer Fill Hose (2 pack)	PN# 5308815006
Certifications	
ENERGY STAR®	Yes
NSF® Certified Sanitize/Allergen	
Specifications	
Power Supply Connection Location	Right Top Rear
Water Inlet Connection Location	Left Top Rear
Voltage Rating	120V/60Hz/15A
Connected Load (kW Rating) @ 120 Volts¹	1.1
Watts @ 120 Volts/Amps @ 120 Volts	1,100/10
Minimum Circuit Required (Amps)	15
Shipping Weight (Approx.)	222 Lbs.

¹For use on adequately wired 120V, dedicated circuit having 2-wire service with a separate ground wire. Appliance must be grounded for safe operation.

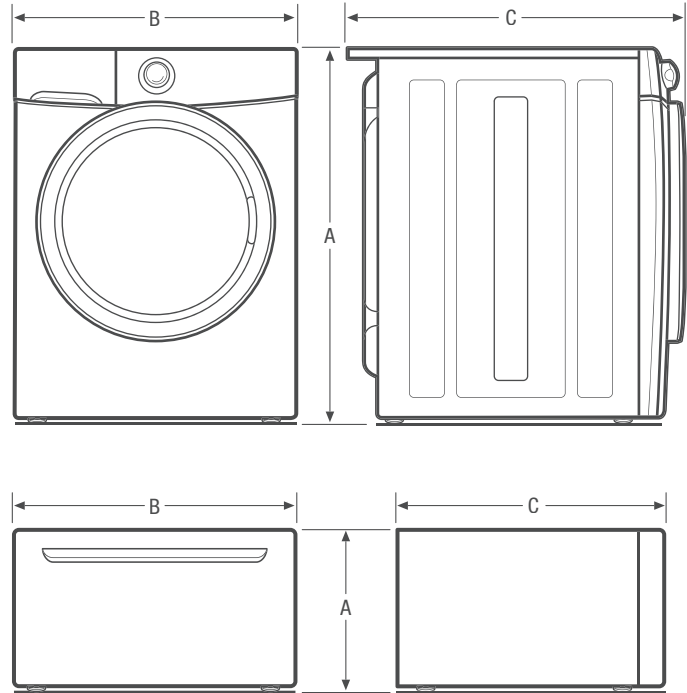

NOTE: For planning purposes only. Always consult local and national electric and plumbing codes. Refer to Product Installation Guide for detailed installation instructions on the web at frigidaire.com.



Product Dimensions	
A - Height (Single)	36"
Height (Stacked)	71-1/2"
B - Width	27"
C - Depth	30-9/16"
Depth with Door Open 90°	50-13/16"
Pedestal Dimensions	
A - Height	15-1/4"
B - Width	27"
C - Depth	26-1/2"
Depth with Drawer Fully Extended	42-1/2"

Accessories information available on the web at frigidaire.com

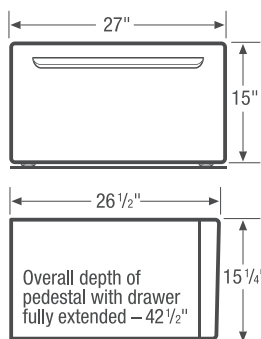
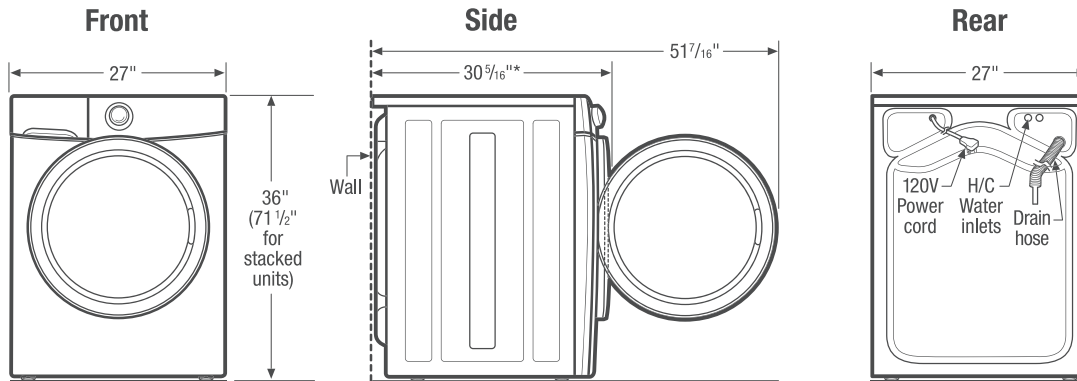

15" Pedestal Drawer Installation

Elevates washer height to 51 1/4". For detailed pedestal installation, refer to instructions included with pedestal or on web. **Note:** Pedestal Installation requires modified utility hookup locations. For details, refer to Product Installation Guide on web.

Built-In Installations

For built-in washer/non-steam dryer installations, NO minimum clearance required around sides or backs of units (see built-in illustrations). For washer installation with steam dryer, additional 3/4" steam hose clearance required at back of dryer. For closet installation, allow additional 1" clearance between fronts of units and door. Location of plumbing, exhaust and utility hookups MUST be considered in built-in installations. For additional installation details, refer to Product Installation Guides on web.

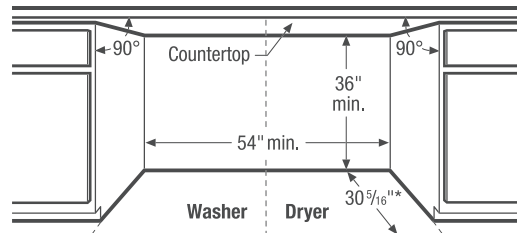

Side-by-Side Units in Under-Counter Installation

Can be installed with standard countertop and/or cabinetry.

* To achieve minimal installation depth dimensions, dryer MUST be vented straight back. For installation with quick-turn 90° elbow, refer to Product Installation Guide on web for approximate clearances incurred with multi-directional exhausting options in freestanding, pedestal-mounted, or stacked installation.

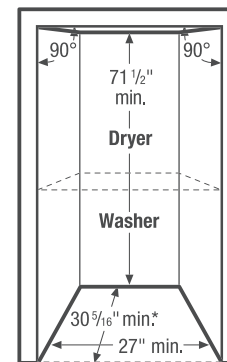

Stacked Units in Recessed or Closet Installation

For detailed stacked installation, refer to instructions included with Stacking Kit or on web. **Note:** Stacked installation requires modified utility hookup locations for dryer. For details, refer to Product Installation Guide on web.

Front Load Washer Specifications

- Product Shipping Weight (approx.) - 222 Lbs.
- An electrical supply with grounded three-prong receptacle is required. The power supply circuit must be installed in accordance with current edition of National Electrical Code (ANSI/NFPA 70) and local codes & ordinances. (Do not use same circuit as dryer.)
- Voltage Rating - 120V / 60 Hz / 15 Amps
- Amps @ 120 Volts = 10 Amps
- Equipped with 120V 3-wire power supply cord, approx. 60" long.
- Always consult local and national electric & plumbing codes.
- To maximize detergent effectiveness, ambient temperature should never be below 60° F.
- Can be installed alone, with or without optional 15" Pedestal Drawer, or stacked below matching Frigidaire® Dryer, which requires installation of optional Dryer Stacking Kit. (For installation details, refer to instructions included with optional pedestal or stacking kit or on web.)
- Can be built in with matching Frigidaire® Dryer in under-counter, recessed or closet installation. (Refer to Built-In Installations on this page for cutout dimensions. For additional installation details, refer to Product Installation Guide on web.)
- Closet installation requires vented door with 2 unobstructed louvered openings, minimum 60 sq. in. each, located 3" from top and bottom of door. Full-length 120 sq. in. opening also acceptable. Allow additional 1" clearance between fronts of units and closed door.
- Do NOT install in area exposed to dripping water or outdoor weather conditions, or where gasoline or other flammables, including automobiles, are kept or stored.

- Floor MUST be solid with 1" maximum slope. To minimize vibration or movement, reinforcement of floor may be necessary. Do NOT install on carpeted surface.
- Leveling legs supplied to level washer properly and reduce excessive noise and vibration.
- H/C water faucets MUST be installed within inlet hose length of washer's water inlet and MUST be 3/4" to connect to inlet hoses.
- Water pressure MUST be between 30 and 120 psi with NOT more than 10 psi pressure difference between hot and cold.
- Drain required with standpipe diameter of 1-1/4" min. and height of 24" min./96" max. above floor, capable of eliminating 17 gallons per minute. Attached 59" drain hose can reach 74"-high standpipe. For higher standpipe, optional Drain Hose Extension Kit available.

Note: For planning purposes only. Refer to Product Installation Guide on the web at frigidaire.com for detailed instructions.

Optional Accessories

- Dryer Stacking Kit - (PN# STACKIT4X).
- 15" Classic White Pedestal Drawer - (PN# CFPWD15W).
- Mobile Home Installation Kit - (PN# 137067200).
- Drain Hose Extension Kit - (PN# 137098000).
- 6' Stainless Steel Washer Fill Hose (2 pack) - (PN# 5305516562).
- 4' Rubber Washer Fill Hose (2 pack) - (PN# 5308815006).